

SPECIAL APPLICATIONS

Flooring & Wall Cladding



GENERAL TERMS

The operations, businesses, and properties described in this manual are owned or operated by CaesarStone® or by various affiliates and subsidiaries of CaesarStone®. The terms "CaesarStone®" "company," "we," "our," and "its" when referring to these entities are used only for convenience and are not intended to be an accurate description of ownership, operation or corporate/legal relationships.

You are permitted to access and read the Technical Support Manual in accordance with the following terms and conditions:

1. The contents of this Technical Support Manual may be used for informational, non-commercial purposes only. The Technical Support Manual is intended to provide information about CaesarStone® products to fabricators and installers.
2. Except as otherwise provided in these Terms, you may not copy the Technical Support Manual or any portion thereof, for any purpose. No part of the contents of Technical Support Manual may be distributed, modified, transmitted, reused, reposted, translated into any language or any computer language or otherwise used without the express written permission of CaesarStone® except as provided herein.

Using the Technical Support Manual indicates that you accept these Terms.

DISCLAIMER

This Technical Support Manual contains general guidance, suggestions and tips accumulated by CaesarStone® pursuant to years of experience in the field. However, many factors such as product location, exposure to weather, temperature, sunlight and other conditions, quality of installation, improper, insufficient or poorly designed support, cabinets, structures, substrate or sub-floors for the CaesarStone® surfaces and/or quality of installation materials, may damage the CaesarStone® surfaces.

Therefore, while CaesarStone® uses reasonable efforts to include accurate, helpful and up-to-date information within the Technical Support Manual, CaesarStone® makes no warranties or representations as to its accuracy, completeness, correctness, and/or suitability or application under any particular circumstances. CaesarStone® assumes no liability or responsibility for any act and/or omission performed by anyone based on or due to the content of the Technical Support Manual, and/or due to any typographical or other errors or omissions in the content.

Furthermore, except to the extent expressly stated in a specific warranty certificate provided by CaesarStone® with its products (and subject to the exclusions provided therein) or otherwise required by applicable law, CaesarStone® disclaims all warranties and representations, expressed or implied, statutory or otherwise, including without limitation, any implied or expressed warranties of merchantability or fitness for a particular purpose, and shall not be responsible or liable, in either contract or tort, for any loss and/or damage, including, without limitation, direct, indirect, special, consequential or incidental damages, arising out of the use and/or inability to use and/or delays in installation of, or repairs to the surfacing products provided or to be provided by CaesarStone®, when they are used for flooring and/or walls.

In any event and without derogating from the above, CaesarStone® Sdot-Yam Ltd. does not accept any responsibility for any damage caused to its products by unauthorized and/or non-certified personnel.

Please note that the content of the Technical Support Manual is provided as a supplementary form of information and is not intended to replace or supersede the obtainment of professional advice, guidance and services as may be required by you and/or your particular circumstances in connection with the products, their use, installation, repair and the like. In any event, please obtain professional services and guidance when dealing with the products.

TRADEMARKS

CaesarStone®, CaesarStone® logo, CaesarStone® graphics, photos and other icons and graphic symbols are registered trademarks and/or service marks of CaesarStone®. Nothing contained in the Technical Support Manual should be construed as granting, by implication or otherwise, any license or the right to use these marks without express written permission of CaesarStone®.

COPYRIGHT

As between CaesarStone® and you, CaesarStone® is the sole owner of all content in this Technical Support Manual including, without limitation, all applicable patents, trademarks, copyrights (including, but not limited to, selections, collections, compilations, and arrangements), and other intellectual property rights thereto. The copyright to the contents of the Technical Support Manual is owned by CaesarStone®.

©Copyright CaesarStone 2010. All rights reserved.

Manual Version Number: 01-0610

Email: customer-service@caesarstone.com
www.caesarstone.com



Contents

1.	Product Information	1
2.	Safety	2
2.1	General Safety Procedures.....	2
2.2	Working in Areas with Hazardous Silica Dust	3
3.	Installation of Flooring and Wall Cladding	4
3.1	Introduction.....	4
3.2	Substrates.....	5
3.3	Surface Preparation.....	5
3.4	Pre-installation.....	5
3.5	Adjoining Flooring and Wall Cladding.....	6
3.6	Laying and Bonding the Material	7
3.7	Movement Joints and Grout Joints.....	10
3.7.1	Applying Grout and Caulk	
3.8	Fabrication Guidelines for Flooring and Wall Cladding.....	12
3.8.1	Cutting	
3.8.2	Drilling Holes	
3.8.3	Polishing Edges	
3.8.4	Corner Installations	
3.8.5	Fixtures	
3.9	Skirting Boards.....	15
3.10	Stairs	15
3.11	Underfloor Heating	15
3.11.1	Installing the Underfloor Heating System	
3.12	Wall Cladding.....	16
3.12.1	Bonded Wall Cladding and Mechanical Reinforcement Ties	
3.12.2	Dry Installation of Wall Cladding	
3.12.3	Wall Cladding over a Sloping Floor	
3.13	Post-installation Procedures	19
4.	Care & Maintenance.....	20
4.1	Heat Resistance.....	20
4.2	Scratch Resistance.....	20
4.3	Honed, Textured/Viento and Motivo Finishes: Care & Maintenance.....	20
4.4	Stubborn Stains or Dried Spills.....	21
4.4.1	Recommended Stain Removers	
4.4.2	Treating Stains	
5.	Technical Data.....	24
6.	CaesarStone Certification	26

General

This document is one in a series of technical documents providing recommended guidelines for working with CaesarStone® quartz surfaces.

- For further information on our training programs, please contact: customer-service@caesarstone.com.



Safety

- Ensure that all electrical tools operate at the correct voltage and comply with local safety regulations.
- Ensure that there is adequate ventilation in the work area.



Important

- If you must use an unfamiliar material, check its suitability by applying it to a small area of the surface that is not visible.
- Slabs from different batches may vary slightly in shade. Always try to use the same batch for the whole job, or carefully match the shade when using slabs from different batches.



Tools

Refer to the Technician's Toolkit manual for a detailed list of recommended tools and materials.

Legend

The following symbols are used in this manual:



Important



Tip

1. Product Information

CaesarStone slabs are manufactured in the following dimensions:

- Size: 1440 mm (± 5 mm) x 3050 mm (± 10 mm); (56½" x 120")
- Thickness: 30 mm, 20 mm, 13 mm (± 1 mm); (1¼", ¾", ½")

CaesarStone slabs can be cut to any size and shape required, enabling versatility in fabrication and design.

CaesarStone material used for flooring and wall cladding must have beveled edges.

 Imperial measurements (feet and inches) appearing in this manual are approximate only.



2. Safety

2.1 General Safety Procedures

CaesarStone has always been at the forefront of creating a safe work environment. We require our distributors, fabricators and installers to follow the same level of commitment regarding safety and to comply with local occupational, safety and health regulations.

- Maintain a clean and neat working environment. Cluttered areas invite accidents.
- Keep working areas dry, well ventilated and well lit.
- Keep children and visitors at a safe distance from the work area.
- Do not overreach. Keep proper footing and balance at all times.
- Maintain a fully equipped first-aid kit on site.
- Read the instruction manuals pertaining to the tools used. Learn the tools' application, maintenance, limitations and potential hazards.
- Use the appropriate tools. Do not use tools or attachments for functions or at speeds for which they were not designed. Do not use improvised tools.
- Maintain tools in top condition. Keep tools sharp and clean for best and safest performance.
- All electrical tools must be equipped with a Ground Fault Circuit Interrupter (GFCI). Three-prong plugs must be plugged into three-hole electrical sockets. If an adapter is used to accommodate a two-prong socket, the adapter plug must be attached to a known ground. Never remove the third prong.
- Use clamps or a vise to secure work when necessary, freeing both hands to safely operate tools.
- Always remove keys and wrenches. Check that keys and adjusting wrenches are removed before switching on the tool.
- Do not wear loose clothing, neckties, rings, bracelets or other jewelry that may get caught in moving parts.
- Wear the following protective apparel when fabricating CaesarStone quartz surfaces:



- Hair covering to contain long hair
- Safety helmet when handling and transporting
- Dust mask
- Nonslip, steel-capped safety shoes
- Safety glasses or other approved eye protection.
- Earplugs when working in noisy areas
- Gloves for protection against chemicals or rough material
- In wet areas, aprons and steel-capped rubber boots in addition to the above

2.2 Working in Areas with Hazardous Silica Dust

THE DISTRIBUTOR IS EXPECTED TO PROVIDE ITS CUSTOMERS WITH ALL RELEVANT INFORMATION RELATED TO WORKPLACE SAFETY AND HEALTH, PARTICULARLY IN AREAS WITH SILICA DUST.

CaesarStone slabs and products are not hazardous as shipped and used by the end customer. However, CaesarStone slabs contain crystalline silica (quartz), and their fabrication and processing (i.e., cutting, sawing, grinding, breaking, crushing, drilling, sanding or sculpting) generate dust.

Unprotected and uncontrolled exposure to such dust is dangerous to health and can cause severe illnesses, such as: silicosis, lung cancer, fibrosis of the lungs, tuberculosis, kidney diseases, abrasion of the cornea, and irritation of the skin and eyes. Preexisting physical disorders may aggravate the adverse affects of exposure to silica dust.

If irritation of the eyes or skin is experienced, flush the area immediately with plenty of water. If breathing difficulties are experienced, move outdoors into fresh air. In any event of physical discomfort, consult with a physician.

Wherever this product is fabricated and processed, a silica control program shall be in place in accordance with all the applicable laws, regulations, orders and directives. The permissible exposure limits to silica dust shall also be met.

Requirements of the Occupational Safety & Health Administration appear at www.osha.gov; the International Labor Organization at http://www.ilo.org/safework/info/lang--en/WCMS_108566/index.htm; and the European Network for Silica at <http://www.nepsi.eu/good-practice-guide.aspx>.

In addition to any other applicable safety measures, the safety rules below must be followed to ensure employee safety:

- Display a "Hazardous Dust" sign in all areas with hazardous dust.
- Wear a suitable dust mask in all areas displaying a "Hazardous Dust" sign.
- Use dust control systems. Check that the dust intake, filtration and expulsion systems are functioning correctly.
- Use wet tools to prevent airborne dust particles.
- Check that the work area is clean at the end of each shift.
- Wear protective apparel when cleaning and maintaining machinery.
- Wear designated work apparel at the worksite, including shoes and socks. Change into work clothes at the worksite. Shower and change into clean clothes before leaving the worksite. Wash the clothes before reuse.
- Do not clean work clothes, machines or floors with compressed air. Perform cleaning only with a suitable vacuum cleaner.
- Eating, drinking and smoking are permitted only in designated areas that are not exposed to hazardous dust.
- Wash hands and face before eating, drinking and smoking.
- Workers must undergo medical tests as required by local regulations.



3. Installation of Flooring and Wall Cladding

3.1 Introduction

This document provides guidelines for the installation of CaesarStone flooring and wall cladding.

CaesarStone slabs are suitable for use as flooring, wall cladding, countertops, stairs, elevator cladding, bathrooms, whirlpools, spas and many other applications.

CaesarStone material is intended for interior use only.

Installation of CaesarStone material must be carried out according to relevant local standards and safety regulations.

It is recommended that installation be performed by a skilled, experienced installer.

The installer, in consultation with the construction engineer, must ascertain that the physical properties (friction coefficient, thermal expansion, etc.) of the particular type and finish of CaesarStone material selected for installation are suitable for the specific environment.

CaesarStone material must be cut with water-cooled diamond cutting tools.

Anti-slip treatment may be applied to CaesarStone flooring if considered advisable by the construction engineer or if required by local regulations.

CaesarStone does not provide warranty for flooring or wall cladding applications. CaesarStone is responsible only for proven manufacturing defects in the products. Contact your local distributor for the CaesarStone warranty policy.

Dedicated brochures with specific product recommendations by Laticrete, Mapei and Ardex for the installation of CaesarStone material are available from CaesarStone.

In any case of conflict or ambiguity between instructions provided in this manual and instructions provided by the product manufacturers, follow the product manufacturer's instructions.



3.2 Substrates

Substrates to receive CaesarStone material must be in conformance with the International Residential Code (IRC) for residential applications, the International Building Code (IBC) for commercial applications, or applicable building codes. Substrates must comply with relevant local standards and project requirements.

Instructions regarding substrates relate to both horizontal and vertical substrates unless otherwise specified.

Substrates must be able to withstand the weight and the forces of the application and be suitable for the environmental conditions, e.g., high temperature or wet areas.

CaesarStone material can be applied over substrates of concrete, concrete block, masonry-type surfaces, gypsum wallboard, plaster, cement backer board, plywood, steel and other substrates, with the proper preparation and the use of the appropriate installation products according to the product manufacturer's instructions.



Ensure that plasterboard substrates conform to the required standards to bear CaesarStone wall cladding.

Substrates must be flat and level to within 3 mm per 2 m (approximately 1/8" per 79") length. If necessary, use a self-levelling compound to achieve this on floors, and render on walls. These factors directly affect the quality of the installation.

Substrates may be existing or new. New substrates must be dry and cured as per the manufacturer's recommendations.

Substrates must be stable, solid and clean of dirt, debris, curing compounds, paint overspray and excessive laitance before installing CaesarStone material.

3.3 Surface Preparation

The substrate surface must be prepared for effective bonding of the adhesive, as per the adhesive manufacturer's instructions.

If the substrate is new, remove debris, sweep, vacuum and wash the substrate. Allow the substrate to dry completely before proceeding to the next stage.

If deep cleaning of the substrate surface is required, e.g., on an existing substrate, this can be performed by chemical means or by mechanical means such as diamond grinding or shot blasting.

3.4 Pre-installation

Verify that all the pieces are the correct size, color and thickness.

Verify that all same-colored pieces to be laid in one area are from the same batch.

Select the appropriate products according to the conditions and requirements of the installation, in consultation with the construction engineer.

Verify that the environmental conditions meet the requirements for the products selected.

Bear in mind that various parts of an installation may require different installation products due to environmental conditions, e.g., higher temperatures under windows, skylights and other areas exposed to UV light; underfloor heating; proximity to fireplaces, heaters, or other direct heat sources.

Ensure that the installation products are suitable for the temperature to which they will be exposed.

In wet areas, apply an appropriate waterproofing membrane. If necessary, apply an appropriate soundproofing/crack isolation membrane.

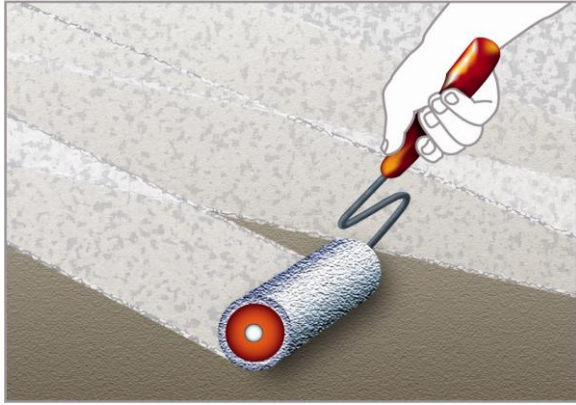

Apply primer on the back of the material and/or substrate if required for the chosen adhesive.

Plan the stages of the application, e.g., the starting point of the flooring/wall cladding, height of flooring/wall cladding, parallel lines, expansion and grout joint sizes, matching of joints to structural expansion joints, circumferential joints, positioning of pieces for design considerations.

3.5 Adjoining Flooring and Wall Cladding

Most installations have adjoining flooring and wall cladding.

There are two methods of installing CaesarStone material as adjoining flooring and wall cladding. In both methods, the wall cladding is carried by the adhesive and/or mechanical anchoring; there is no direct contact between the wall cladding and the wall substrate or the flooring.

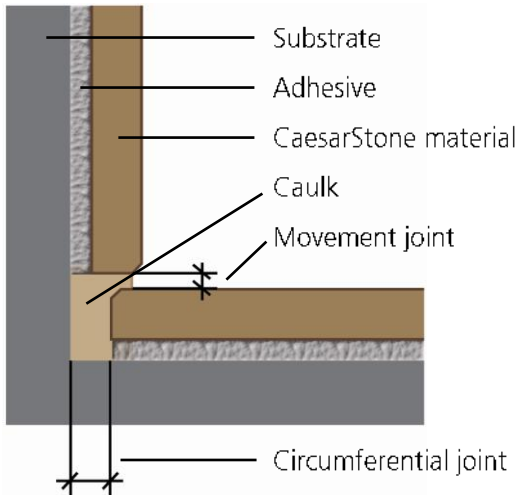

Method 1 – Installing Flooring Before Wall Cladding

This is the more popular method of installing adjoining flooring and wall cladding:

1. Lay the flooring with a circumferential joint of 5-10 mm ($\frac{3}{16}$ - $\frac{3}{8}$ ") from the wall substrate.
2. Fill the circumferential joint with caulk.
3. Place dividers horizontally on the surface of the flooring next to the wall.
4. Install the wall cladding on the dividers to create a movement joint.
5. When the wall cladding adhesive is dry, remove the dividers and fill the movement joint with caulk.

Advantages:

- The leveled floor provides a level base for the wall cladding.
- The circumferential joint can be easily created.
- The circumferential joint can be properly sealed.
- The wall cladding conceals the circumferential joint and any inexact angles of the wall.

Disadvantages:

- The flooring adhesive must be completely dry before installing the wall cladding.
- The fresh flooring can easily be damaged during the installation of the wall cladding.

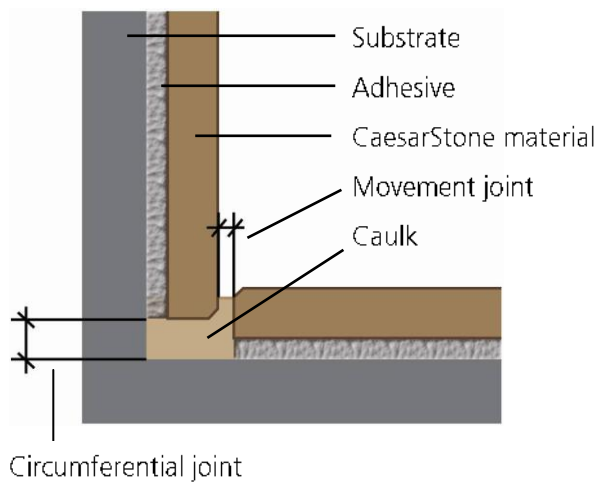

Method 2 – Installing Wall Cladding Before Flooring

1. Install the wall cladding with a circumferential joint of 5-10 mm ($\frac{3}{16}$ - $\frac{3}{8}$ ") over the floor substrate.
 -  Use wedges to create circumferential joints in order to compensate for uneven substrates.
2. Fill the circumferential joint between the wall cladding and the floor substrate with caulk.
3. When the wall cladding adhesive is dry, remove the wedges.
4. Lay dividers vertically against the bottom of the wall cladding.
5. Lay the flooring against the dividers, abutting the wall cladding, to create a movement joint.
6. When the flooring adhesive is dry, remove the dividers and fill the movement joint with caulk.

Advantages:

- There is no risk of damage to the flooring.
- The adhesive on the wall has to undergo only initial drying before installing the flooring.
-  Flooring can be installed immediately after the wall cladding by using short wedges that do not reach the outer edge of the wall cladding. These wedges remain in place when the flooring is laid.

Disadvantages:

- If the floor substrate is not level, it is more difficult to level the wall cladding.
- It is more difficult to align the perimeter of the flooring to the walls.

3.6 Laying and Bonding the Material



Select the appropriate adhesive for the installation according to the product recommendation brochures. Cementitious adhesives are suitable for areas that are not subject to high temperatures or exceptionally strong forces or weight. For these areas, use adhesives containing flexible material as recommended by the adhesives manufacturer.

Prepare the appropriate adhesive. The adhesive may be in a ready-to-use paste form, or pastes/powders that require mixing. The prepared adhesive must be completely smooth and easy to spread.

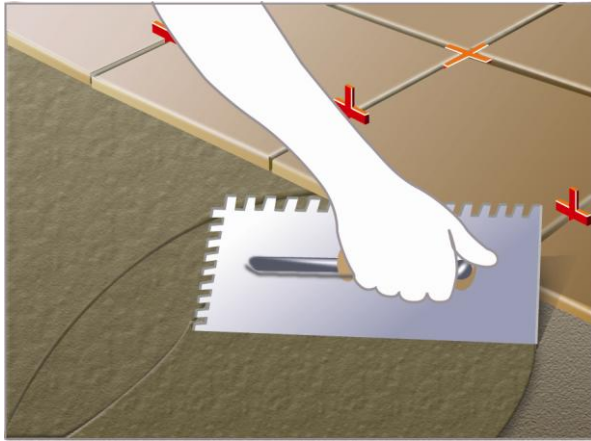

Prepare only the amount of adhesive that can be applied before drying reduces applicability and adhesiveness.

Firmly spread a thin layer of the prepared adhesive with the straight edge of a trowel. Cover an area on which the material can be laid while the adhesive is wet and sticky. The area will vary depending on the site conditions and environmental factors.

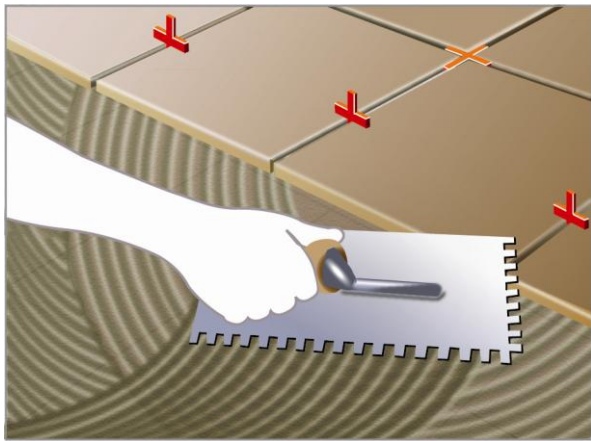

Next, spread a layer of the adhesive with the notched edge of the trowel on the same area of substrate. The notched trowel creates uniform thickness when spreading the adhesive.

Use a notched trowel of sufficient size to provide full coverage of the material with the adhesive.

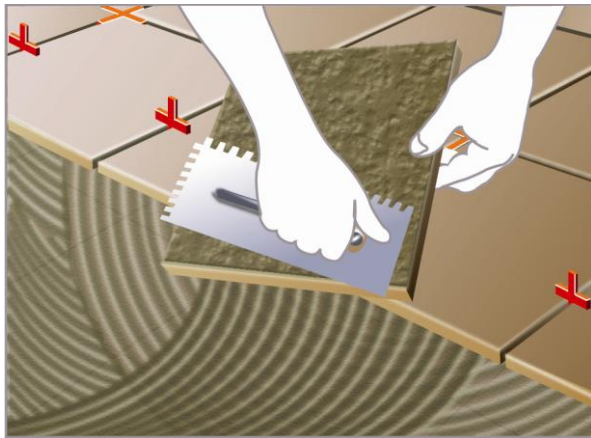

Firmly spread a thin layer of the adhesive with the straight edge of the trowel on the back of the piece of material to be laid (back buttering).

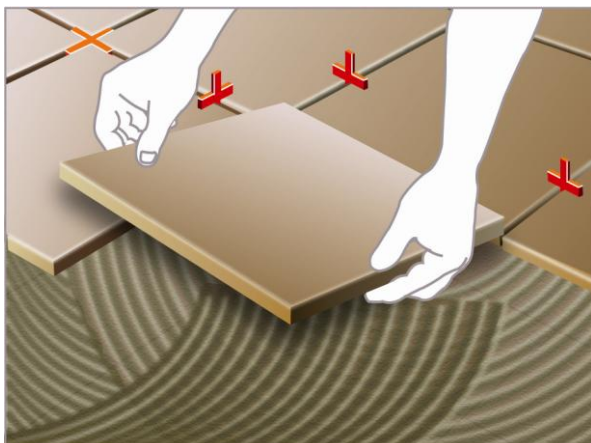

Lay the material on the substrate.



Press the material into the adhesive with a side-to-side movement using both hands in order to ensure that no air remains between the tile and the adhesive, and to ensure complete contact.

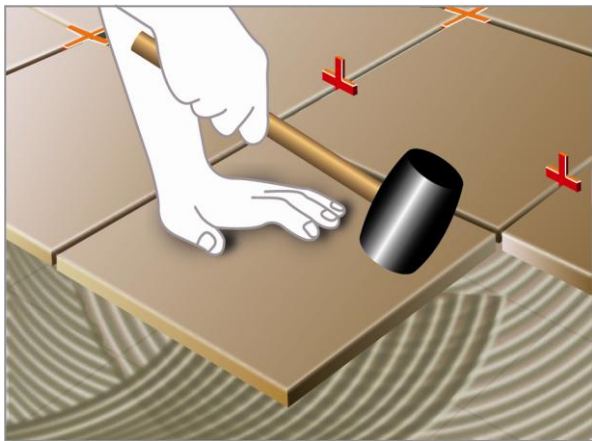

Use a rubber mallet to level the material.

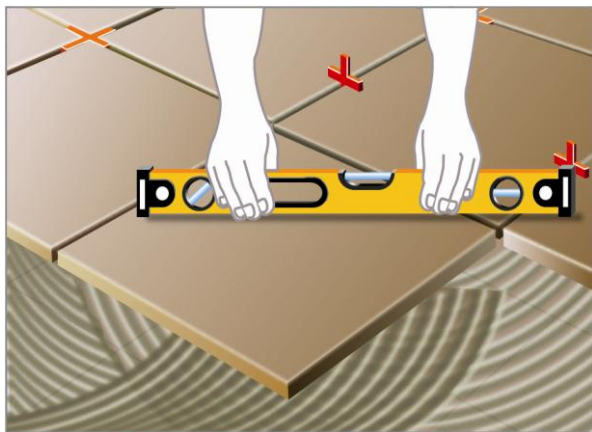

Ensure the level and flatness of each piece of material individually, and the relation between pieces (horizontal or vertical), by consistently using a spirit level during installation. The height difference between tiles must be within permitted local standards – generally 1 mm ($\frac{1}{32}$ ") per 5 mm ($\frac{3}{16}$ ") joint, or 1.5 mm for larger joints.

After installing approximately 2 m² (79"?) of material, check the flatness of the area in several directions with a suitably long spirit level. The flatness must be within the permitted deviation according to local standards – generally 3 mm ($\frac{1}{8}$ ") per 2 m length.

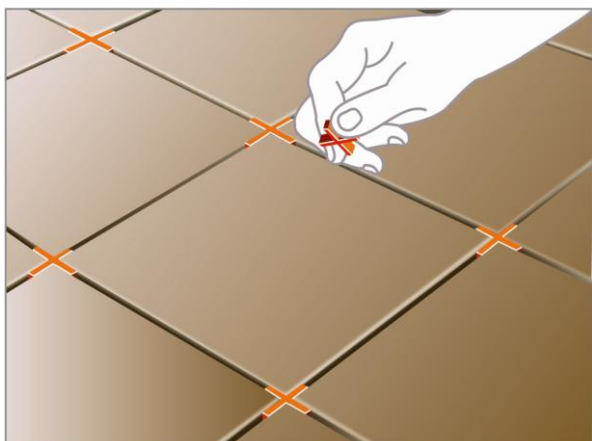

Create the space for all joints between the pieces with dilatation strips or tile spacers.

Clean excess adhesive off the material with a clean, wet sponge while it is still fresh.

After every few meters of laying the material, lift one piece to check that the adhesive is spread evenly.

After the adhesive is completely dry, and before grouting, test the adhesive strength of the material by trying to remove pieces in various places.

Prevent traffic of people, animals and construction equipment on the installation until permitted by the product instructions.

3.7 Movement Joints and Grout Joints

Movement joints or grout joints must be created between pieces of CaesarStone material for the following purpose:

- to enable expansion, contraction and movement of all the materials that comprise the floor (CaesarStone material, substrate and installation materials), thereby preventing forces developing that may cause shearing and detachment of the flooring material
- to mask any differences in height between the edges of the pieces of material

The size of the joints is determined by the adhesive and grout manufacturer, according to the following considerations:

- type of substrate
- material dimensions
- environmental conditions
- thermal expansion coefficient of the CaesarStone material, substrate and installation materials
- specific requirements of the construction engineer
- esthetic considerations

Grout joints are filled with grout.

Movement joints are filled with caulk. They are located between pieces of material around areas of approximately 30 m² (100 ft.²), and in higher movement areas such as:

- between materials on the same plane with different thermal expansion coefficients
- inside or outside corners
- aligned with structural expansion joints



If movement joints are not aligned with structural expansion joints, it is likely that movement of the structure will cause the material to lift and/or crack.

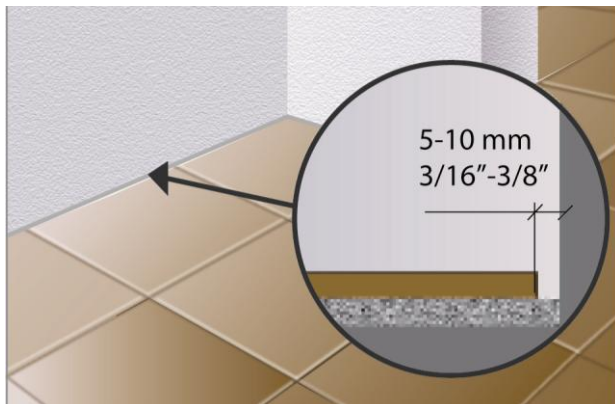

Circumferential joints are a type of movement joint.

A circumferential joint is a space between perpendicular planes to allow for expansion, contraction and movement.

Allow circumferential joints of 5-10 mm ($\frac{3}{16}$ - $\frac{3}{8}$ ") between the material and the substrate of any perpendicular construction elements.

Fill the circumferential gap with flexible caulk.

3.7.1 Applying Grout and Caulk

Before applying grout or caulk, clean dirt or debris out of the joints by sweeping and/or vacuuming. Wipe the surface of the material with a wet cloth. Fill the joints only after the adhesive is dry according to the manufacturer's instructions.



Do not allow water, cleaning materials, chemicals or any other liquid to enter the joints as they may be trapped under the material when the joints are sealed and cause damage that may lead to detachment of the flooring material.

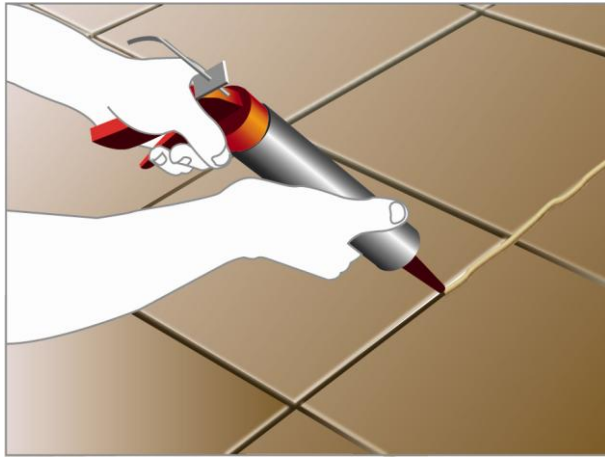

Fill the movement joints with the appropriate caulk.



Shape and smooth the caulk in the movement joints. Remove the deposits from the surface of the tiles with a scraper. Wipe off the remaining deposits with a damp sponge.



Fill the grout joints with the appropriate grout, using a hard rubber float.

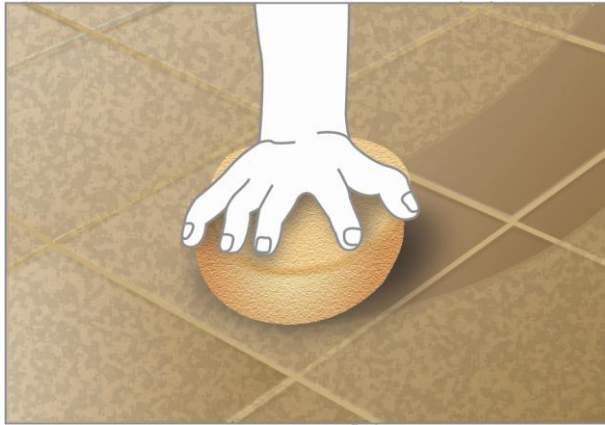

Shape and smooth the grout in the grout joints.

Remove the deposits from the surface of the material with a scraper. Wipe off the remaining deposits with a damp sponge.

Take care not to inadvertently extract the caulk/grout from the movement/grout joints.

3.8 Fabrication Guidelines for Flooring and Wall Cladding

During the installation of flooring and wall cladding, it is necessary to cut and fabricate pieces according to the requirements of the project.

This section provides limited fabrication guidelines specific to flooring and wall cladding. Detailed fabrication instructions can be found in CaesarStone University's *Fabrication & Installation* manual.

3.8.1 Cutting

Cut the material to the correct size using a water-cooled diamond disk. It is recommended to cut the material on a portable, bench-mounted machine. If no portable machine is available, a manual disk can be used.

If it is necessary to create cutouts in the material, e.g., for electrical outlets and accessories, fabricate rounded inside corners of at least 15 mm ($\frac{3}{4}$ "), and position the cutouts at least 50 mm (2") from the edge.



It is not recommended to create L-shapes as one piece from the material. Instead, create the L-shape from two pieces joined at the inside corner.

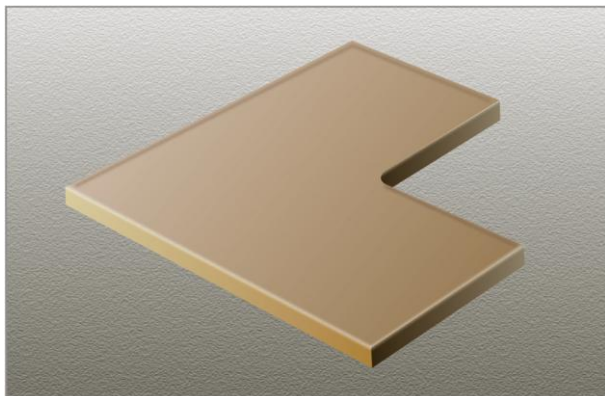

 If, however, the circumstances require the fabrication of an L-shape as one piece, a minimum radius of 15 mm ($\frac{3}{4}$ ") should be fabricated in the inside corner.

3.8.2 Drilling Holes

It is recommended to drill holes with a water-cooled diamond cup drill. If this is not available, use a carbide-tipped drill bit with no hammer action. Gradually enlarge the hole to the required diameter.

Drill holes as far from edges as possible, and in any event, not closer than 50 mm (2") from the edge.

3.8.3 Polishing Edges

Exposed, visible edges must be polished with polishing pads, and sharp corners must be rounded with a diamond grinding wheel and polished. Start polishing with 60 grit and progress through the finer pads to 1500 grit. Do not polish the surface of the material.

3.8.4 Corner Installations

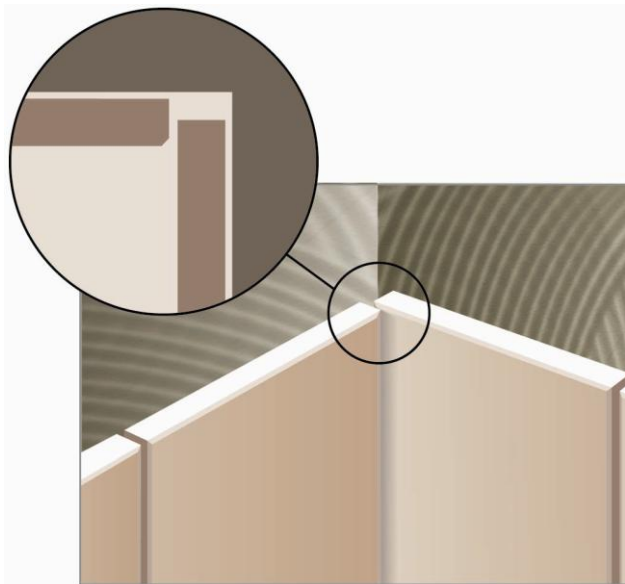

Inside Corners

When installing CaesarStone material on inside corners between walls, or between a wall and a floor or ceiling, leave a circumferential joint of 5-10 mm ($\frac{3}{16}$ - $\frac{3}{8}$ ") between the first piece installed and the perpendicular substrate. Leave a movement joint gap between the second piece installed and the first piece.

Caulk (not grout) the movement joint.

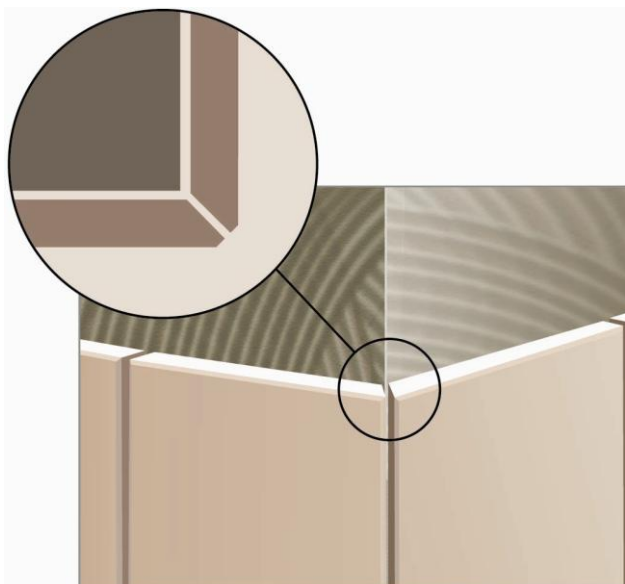

Outside Corners

Method 1: Miter Cut for Any Angle

Cut half the angle required from the two adjoining pieces to create the complete angle.

This is the recommended method as the thickness of the material is not visible. The pieces remain whole and maintain visual consistency with the rest of the wall cladding.

Caulk (not grout) the movement joint.

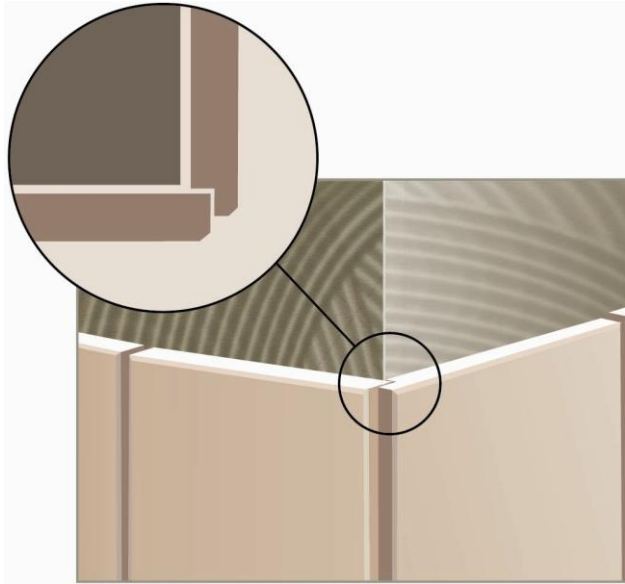

Method 2: for 90° Corners

With this method, a symmetrical 90° angle is created with an equal visual effect from both sides.

Cut a 90° angle from the inside of the edge, to be half the depth and width of the thickness. Polish the two exposed edges.

Caulk (not grout) the movement joint.

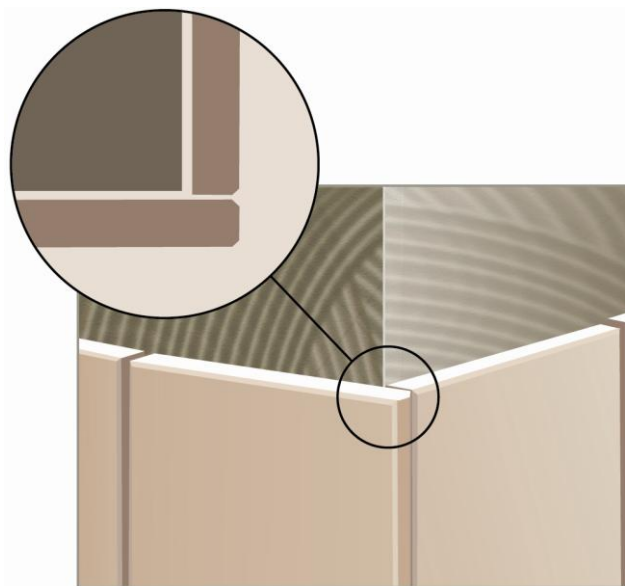

Method 3: for 90° Corners

With this method, the entire edge thickness of one of the pieces is visible and, therefore, requires polishing before it is installed. Cutting is generally not required.

Caulk (not grout) the movement joint.

3.8.5 Fixtures

There are three recommended methods of attaching fixtures to CaesarStone material:

1. Drill a hole of the required size and shape through the material. Attach the fixture to the substrate behind the material with anti-corrosive screws or bolts of the appropriate size and strength, with the screws or bolts slip-fitted through the material.
2. Attach the fixture to the surface using neutral 100% silicone as an adhesive. The larger the area of adhesion, the stronger the bonding.
 -  Some fixtures are supplied with an integral self-adhesive pad, which can be attached directly to the surface.
3. Attach heavy fixtures to CaesarStone material by a combination of both methods above.

3.9 Skirting Boards

Skirting boards made of CaesarStone material may be installed around the base of walls for the following reasons:

- To conceal the circumferential joint between the flooring and the wall.
- To create an esthetic finish on the join between the flooring and the wall.
- To prevent soiling the wall when cleaning the floor.

See section 3.7 regarding circumferential joints.

3.10 Stairs

CaesarStone stairs are fabricated from slabs to the shapes and dimensions required.

Choose the appropriate installation products according to the substrate of the stairs and the environmental conditions.

The method of adhesion, grouting and caulking is the same as for flooring.

It is recommended to install stairs from top to bottom.

Allow circumferential joints of 5-10 mm ($\frac{3}{16}$ - $\frac{3}{8}$ ") between stairs and walls.

Fill the gap with flexible caulk.

It is particularly important to address slip resistance on stairs. Slip resistance can be enhanced by anti-slip treatment, or by the installation of anti-slip grooves, adhesive tape or metal strips. In all cases, slip resistance must comply with local standards.

3.11 Underfloor Heating

Underfloor heating is popular for bathrooms, and can be laid under CaesarStone material flooring. The heating is comfortable, uniform, safe and concealed.

The system temperature is generally set by thermostat and controlled by sensors installed in the room to achieve a surface temperature of 21-24°C (70-75°F) and a subsurface temperature of 24-28°C (75-82°F).

The most widely used systems of underfloor heating are:

- hot water pipes
- electric mats and cables



3.11.1 Installing the Underfloor Heating System

1. Ensure that the substrate is dry, stable, solid and clean of dirt and debris.

2. Lay a waterproofing/crack isolation/soundproofing membrane over the substrate.



In certain circumstances the membrane is laid above the heating system. In this case, ensure that the membrane does not inhibit heat transfer.

3. Lay the heating system over the membrane.



Do not install the flooring material directly on the heating system as this will damage the system.

4. Cover the heating system completely with an even layer of thick bed mortar or an appropriate self-leveling screed. The layer of thick bed mortar or screed that covers the heating system must be properly leveled and flattened so that the next layer can be spread thinly for maximum energy efficiency.

5. After the thick bed mortar or screed has set, fix the CaesarStone material in place with a layer of adhesive.

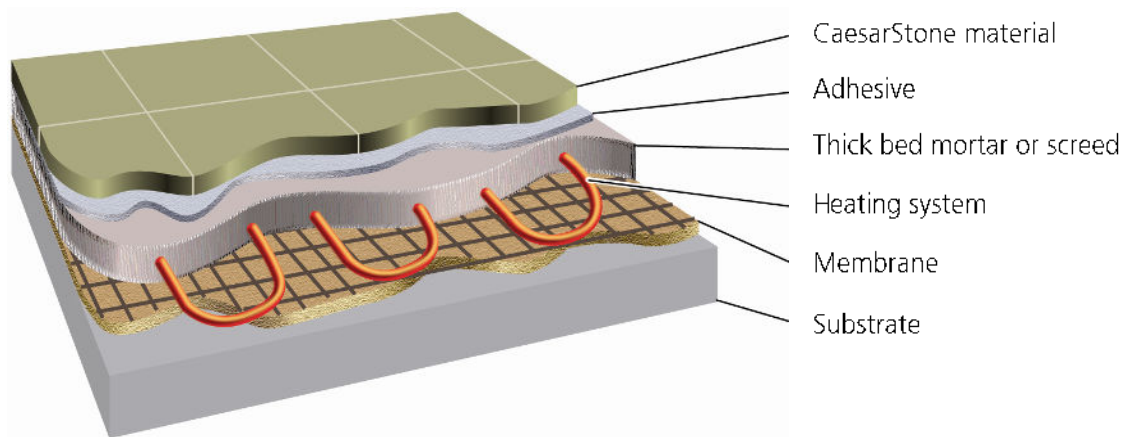

Ensure that all the installation materials used are recommended by the manufacturer for underfloor heating, even though the temperature is not very high.



If it is necessary to drill into the CaesarStone material, take care to avoid damaging the heating system.



Do not turn underfloor heating on, or expose the installation to any other heat source before the adhesive, caulk and grout are completely dry.

3.12 Wall Cladding

Wall cladding may be installed by adhesion only, by adhesion and mechanical reinforcement, or by dry installation, as detailed below.

The information and illustrations provided in this section are intended as general guidelines only. The method of installation and specifications of the wall cladding must be determined by the construction engineer and local regulations.



13 mm (1/2") thickness material is recommended for wall cladding as it weighs less than thicker slabs.

Large expanses of wall cladding can be designed with very few joints by using large pieces of material. Wall cladding pieces are cut from CaesarStone slabs to the shapes and dimensions required. They can be cut to various geometric shapes, with any combination of colors and finishes.

The material is uniform throughout the whole slab, which enables the fabrication of various designs of polished joints, e.g., angled grooves created by enlarged bevels, or square grooves. This characteristic also means that exposed, visible edges can be polished to create an elegant, consistent finish.

Many spaces contain columns, which can be a challenge to clad in an esthetic manner with material of a predetermined size. CaesarStone material can be cut to the exact dimensions required to clad columns with whole pieces per side, providing a technically efficient and visually pleasing solution.

3.12.1 Bonded Wall Cladding and Mechanical Reinforcement Ties

Bonded wall cladding is attached to the substrate by the same method as flooring, using installation products suitable for vertical application. Mechanical reinforcement ties are added if required by local standards and/or the construction engineer. There are two main methods of installing bonded wall cladding:

1. The material is bonded with adhesive only.
2. The material is bonded with adhesive and secured by mechanical reinforcement ties slotted into grooves in the edge of the material.



The purpose of the mechanical reinforcement ties is to prevent the material from falling if it becomes detached from the substrate; or, in addition, to share the load of the material with the adhesive.

Mechanical reinforcement ties are attached to the substrate at several locations as per the manufacturer's instructions, generally by means of screws or an adhered metallic spike inside a predrilled hole.

The ties are attached to the material by means of grooves cut into the thickness of the material. Slight freedom of movement must be allowed between the reinforcement tie and the material for expansion and contraction. The material that remains around the groove must be strong enough to withstand the weight and forces acting upon it.

Installation of mechanical reinforcement ties must be undertaken in strict accordance with the manufacturer's installation instructions. The construction engineer must determine that the mechanical reinforcement system used is appropriate for the purpose, capable of bearing the weight of the CaesarStone material, and that the substrate is suitable for installation of the system.

Mechanical Reinforcement Ties in Bonded Wall Cladding

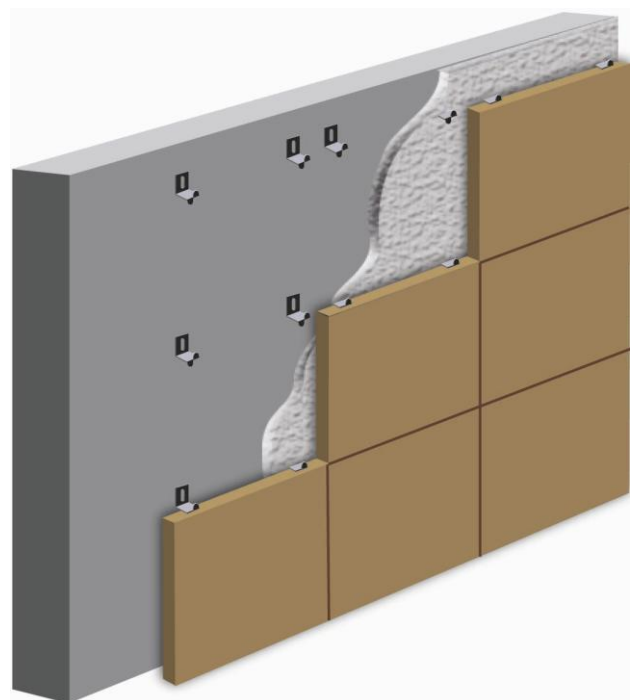
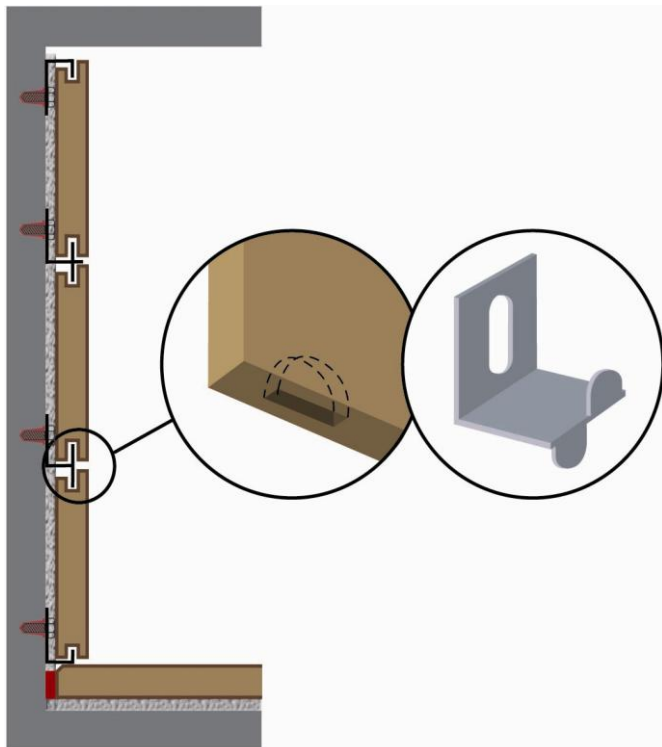

3.12.2 Dry Installation of Wall Cladding

Mechanical profiles are used for dry installation of wall cladding. The dry installation method is often chosen for installation of large pieces of wall cladding, or for other architectural or practical considerations.

 Mechanical profiles in dry installation carry the entire weight of the material and all the environmental forces.

Mechanical profiles do not require the substrate to be perfectly plumb as a space remains between the substrate and the material. The profiles are adjustable to compensate for uneven substrates and to enable alignment of the pieces of material.

Mechanical profiles are generally attached to the substrate by screws or an adhered metallic spike inside a predrilled hole. Slight freedom of movement must be allowed between the profile and the material for expansion and contraction.

Dry installation must be undertaken in strict accordance with installation instructions from the system manufacturer. For full installation instructions, refer to the dry wall cladding installation system supplier manual, available from CaesarStone.

Dry Installation System

Mechanical profiles are attached to the substrate as per the instructions of the manufacturer.

The profiles are attached to the material by means of a groove that runs the entire length of the upper and lower edges of the material.

If the piece of material is very large, one or more flat-edged profiles are generally added at equal intervals in order to prevent bowing.

The width of the profiles is equal to the width of the gap between the substrate and the material. The material is attached to the flat-edged profiles with flexible adhesive.

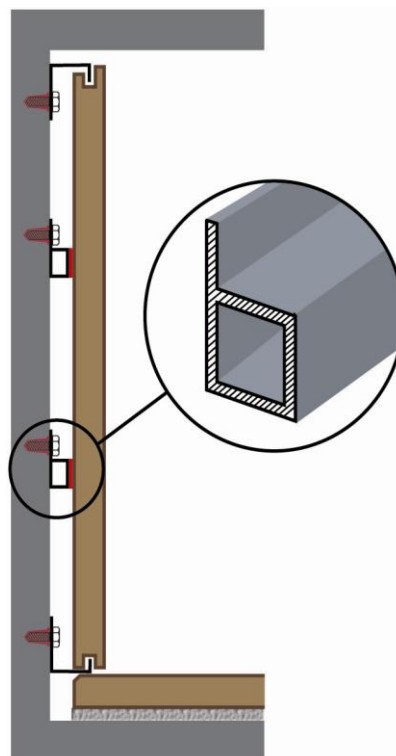
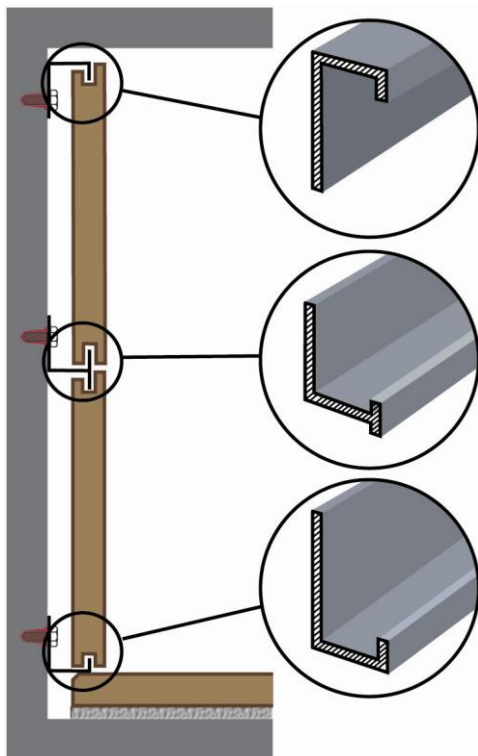

3.12.3 Wall Cladding over a Sloping Floor

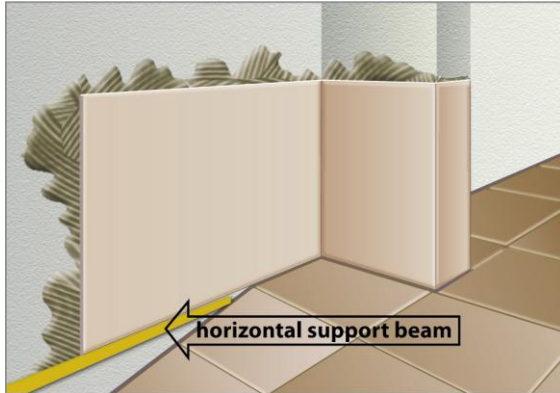

If the floor is on a slope, position a horizontal support beam to provide a level base for the bottom of the wall cladding.

When the material from the beam upwards is dry, remove the beam and complete the lower part with material cut to size.

Follow the instructions in section 3.6 regarding laying and bonding the material.

Follow the instructions in section 3.7 regarding movement joints and grout joints.

3.13 Post-installation Procedures

After the caulk/grout is completely dry according to the product technical data sheets, clean the material using only a neutral pH detergent and water solution to remove all traces of the installation materials.

Clean whitewash and any other materials containing lime off the material immediately.

Anti-slip treatment may be applied to CaesarStone flooring if considered advisable by the construction engineer or if required by local regulations.

Cover the fresh installation to protect it from damage by construction equipment and work taking place in the vicinity.

Residential bathroom – wall cladding 2003; undersink unit 2710



4. Care & Maintenance

Tough, Yes – Indestructible, No

CaesarStone recommends using water and a mild detergent or a high-quality spray and wipe type cleaner on a soft cloth or non-abrasive sponge for routine cleaning of CaesarStone surfaces. Consult with your distributor for specific products recommended in your local market.

- In general, it is recommended to use cleaning products between pH 5-9, as products outside this range may damage the surface.



If cleaning products outside this range are used, as recommended in section 4.4.2, check their effect in advance on a separate piece of the surface.

- It is recommended to leave cleaning products on the surface for no more than 5 minutes.



If it is necessary to leave cleaning products on the surface for more than 5 minutes, check their effect in advance on a separate piece of the surface.

- Do not use products that contain trichlorethane or methylene chloride, such as paint strippers.
- If the surface is exposed to any potentially damaging products, rinse immediately with water to neutralize the effect.
- Do not allow dirt and residue to remain on CaesarStone surfaces for extended periods.
- Products containing oils or powders may leave a residue and should be rinsed off thoroughly.
- Thoroughly rinse cleaning materials off CaesarStone surfaces after use.

4.1 Heat Resistance

CaesarStone surfaces can tolerate moderately hot temperatures for brief periods of time. Prolonged exposure will result in discoloring or other types of damage. Excessive localized heat may damage the surface or cause hairline cracks.



Do not allow direct contact between CaesarStone surfaces and very hot pots or other hot cookware. Always use an insulator/trivet.

4.2 Scratch Resistance

CaesarStone are highly scratch resistant; however, avoid using sharp objects such as sharp knives or screwdrivers directly on the surface.

4.3 Honed, Textured/Viento and Motivo Finishes: Care & Maintenance

These finishes require more routine maintenance than polished finishes due to the different level of smoothness.

- Most marks can be easily removed with a little effort and a recommended cleaning product. For tough stains, gently rub the area with the cleaner and a mildly abrasive pad.



Due to the fact that these finishes are slightly more sensitive to dirt and damage than the polished finish, it is recommended that the surface be covered with a protective layer during fabrication.

4.4 Stubborn Stains or Dried Spills

CaesarStone surfaces are highly stain resistant. If a stain occurs it can usually be easily removed.

- Before treating the stains as described below, try to remove the stain with a damp, soft cloth with water and soap, or a non-abrasive household cleaner.
- For stains with adhered material, such as food, gum, nail polish or dried paint, first scrape away the material with a sharp scraper and then follow the instructions below.

4.4.1 Recommended Stain Removers

Consult with your local distributor for products equivalent to those recommended below.

Organic stains

- Cif® Bathroom Mousse or equivalent
- Astonish® Marble & Granite Clean & Polish (black bottle)

Chemical stains

- Mild, alcohol-based degreasers, such as Windex®
- Alcohol
- Interflon® Fin Degreaser EM30+

Office building reception – flooring 4141; wall cladding 3100, 6140; wall niches Concetto 8141; reception desk 2220, 2141



4.4.2 Treating Stains

Type of Stain	Cause/Source of Stain	Treatment/Remarks
Chemical	<ul style="list-style-type: none"> Materials containing caustic soda pH 10-14 Fat/grease removers, e.g., oven cleaners 	Cannot be removed.
Heat source – direct/indirect	<ul style="list-style-type: none"> Hot pressure cooker Hot frying pan Hot saucepan Polishing burn Toaster oven Grill Hot plate Oven shelves and trays Hot food spillage 	The severity of the burn is indicated by its color. Yellow stains can sometimes be removed with Astonish® Marble & Granite Clean & Polish (black bottle). Brown stains generally cannot be removed.
Oil – natural	<ul style="list-style-type: none"> Olive oil Canola oil, etc. 	<ul style="list-style-type: none"> Astonish® Marble & Granite Clean & Polish 10% bleach Hydrogen peroxide, max. 30% Mild, alcohol-based degreaser
Oil – synthetic	<ul style="list-style-type: none"> Machine oils 	<ul style="list-style-type: none"> Astonish® Marble & Granite Clean & Polish Mild, alcohol-based degreaser
Cosmetics	<ul style="list-style-type: none"> Hair shampoo Medical creams Make-up 	<ul style="list-style-type: none"> Alcohol Astonish® Marble & Granite Clean & Polish Hydrogen peroxide, max. 30%
Metal	<ul style="list-style-type: none"> Metal kitchen tools (e.g., knives) Metal pots Metal belt buckles 	<ul style="list-style-type: none"> Astonish® Marble & Granite Clean & Polish <p>Metal stains may resemble scratches but they are actually metal residue and easily removed.</p>
	<ul style="list-style-type: none"> Rust 	<ul style="list-style-type: none"> Oxalic acid <p>Repeat use for stubborn stains.</p>
Food and beverages	<ul style="list-style-type: none"> Food coloring Herbs and spices Red wine Pomegranates 	<ul style="list-style-type: none"> Astonish® Marble & Granite Clean & Polish 10% bleach Hydrogen peroxide, max. 30% Mild, alcohol-based degreaser
Product imperfections	<ul style="list-style-type: none"> Pigment irregularities 	Drill out the imperfection and repair by plugging (see the <i>Repairing by Plugging</i> manual).
Colors	<ul style="list-style-type: none"> Ink Markers – water based Markers – oil-based (permanent) Paint Print from supermarket bags 	<ul style="list-style-type: none"> Alcohol Astonish® Marble & Granite Clean & Polish 10% bleach
Other	<ul style="list-style-type: none"> Blood 	<ul style="list-style-type: none"> Astonish® Marble & Granite Clean & Polish Hydrogen peroxide, max. 30%
	<ul style="list-style-type: none"> Candle wax 	<ul style="list-style-type: none"> Alcohol Astonish® Marble & Granite Clean & Polish Mild, alcohol-based degreaser
	<ul style="list-style-type: none"> Glue from adhesive tape 	<ul style="list-style-type: none"> Alcohol
	<ul style="list-style-type: none"> Hard water deposits 	<ul style="list-style-type: none"> Scale remover Vinegar
	<ul style="list-style-type: none"> Soap stains 	<ul style="list-style-type: none"> Astonish Mild, alcohol-based degreaser
	<ul style="list-style-type: none"> Shiny area caused by friction (only in honed and Textured/Viento) 	Rub the surface with an abrasive pad until achieving the same surface texture.
	<ul style="list-style-type: none"> Silicone 	<ul style="list-style-type: none"> Alcohol Interflon Fin Degreaser EM30+

Microsoft Shanghai



5. Technical Data

Test Performed	Test Standard	Results
PHYSICAL PROPERTIES		
Water Absorption	ASTM C97	<0.05%
Density	ASTM C97	2.2-2.4 gr/cm ³
	EN 14617-1	2.2-2.4 gr/cm ³
Flexural Strength	ASTM C880	6,500-10,770 psi; 44.8-74.3 MPa
	EN 14617-2*	57.6 -70.0 MPa
Linear Thermal Expansion	ASTM D696	-30 to +30°C: 1.3-1.9*10 ⁻⁵ cm/cm/°C
	EN 14617-11*	-30 to +30°C: 2.1*10 ⁻⁵ (°C ⁻¹); -30 to +60°C: 2.7*10 ⁻⁵ (°C ⁻¹)
Dimensional Stability	EN 14617-12	Class A
DURABILITY		
Impact Resistance	ASTM D1709*	26.3 lbs (117N)
	EN 14617-9:2005-06*	4,000 - 10,000 [J]
Compressive Strength	ASTM C170*	21,312- 27,133 psi
	EN 14617-15*	178.3-210.6 MPa
Abrasion	ASTM C501*	216-696
	ASTM C1243	Volume of chord: V = 132-244 mm ³
	EN 14617-4*	Groove length = 21.8 mm or V = 86 mm ³
Freeze-Thaw Resistance	ASTM C1026*	No defects after 15 freeze-thaw cycles
	EN 14617-5*	No defects after 25 freeze-thaw cycles
Mohs Hardness		6.5-7
STAIN AND CHEMICAL RESISTANCE AND CLEANABILITY		
Stain Resistance**	ANSI Z 124.6	Pass
Wear and Cleanability	ANSI Z 124.6	Pass
Chemical Resistance	ANSI Z 124.6	Pass
	EN 14617-10:2005*	Class C4
THERMAL RESISTANCE		
Boiling Water Resistance	NEMA LD3-3.5	Pass
High Temperature Resistance	NEMA LD3-3.6	Pass
SAFETY		
Cigarette Test	ANSI Z 124.6	Pass
Surface Burning	ASTM E84	Class 1 and Class A
Fire Classification	EN 13501-1*	Wall cladding: B-s1-d0; Flooring and stairs: B-fl-s1
Static Coefficient of Friction	ASTM C1028*	As received – Dry: 0.8; Wet: 0.6
		As renovated – Dry: 0.9; Wet: 0.6
Slip Resistance	DIN 51130*	Oil wet ramp: R9-10
	DIN 51097*	Wet barefoot ramp: C
	EN 14231*	Wet: 13-21 SRV; Dry: 43-53 SRV
	AS/NZS 4586:2004*	Four S rubber pendulum: 25-30 BPN
		Wet barefoot ramp: B
		Oil wet ramp: R10
Radiation	ANSI/N42.14 1999	²²⁶ Ra = 1.4-6.8; ²³² Th = 1.4-3.7; ⁴⁰ K = <3-30.3 (Bq/kg dry weight)

*Results represent a partial series range.

**Some models require scrubbing to remove certain stains.

Wall cladding 3100 Motivo Crocodile



6. CaesarStone Certification

United States Green Building Council (USGBC)



GREENGUARD Low Emitting Products



Scientific Certification Systems
15-40% pre-consumer recycled content in selected colors



Food Equipment Materials ANS/NSF Standard 51



Quality Management System



ISO 9001:2000

Environmental Management System



ISO 14001:2004

Health & Safety System



OHSAS 18001

Kosher – Zomet Institute



Wall cladding 2141 Motivo Lace





Customer Service Department

customer-service@caesarstone.com

www.caesarstone.com

 **caesarstone**[®]
Quartz Surfaces